

# **H** TECHNICAL PROCEDURE

## HUS™ WHEEL-END

SUBJECT: HUS™ Wheel-End Maintenance  
Procedures

LIT NO: L776

DATE: March 2002

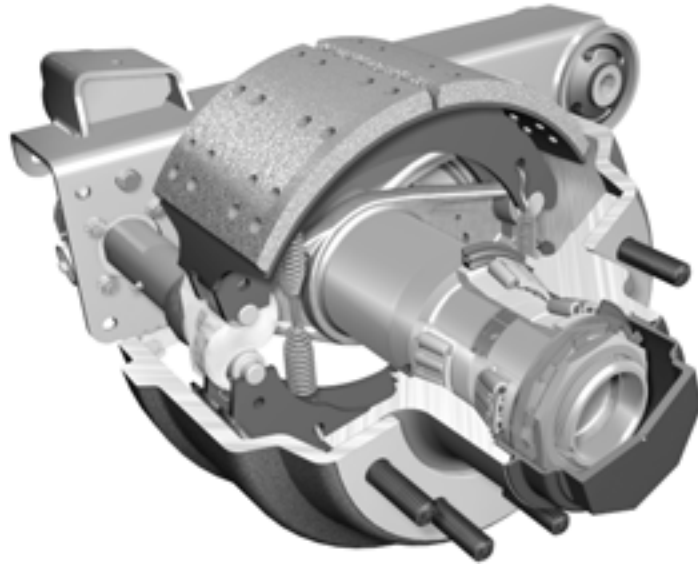

### TABLE OF CONTENTS

SERVICE NOTES AND SAFETY INFORMATION .....	2
INTRODUCTION .....	3
INSPECTIONS AND INSPECTION INTERVALS .....	3
Every Three Months .....	4
Every 12 Months or 100,000 Miles (160,000 Km), Whichever Occurs First .....	4
Checking For Seal Leaks .....	4
Checking For Smooth Rotation .....	4
Checking End Play .....	4
REMOVAL .....	5
INSTALLATION .....	8
HUBCAP O-RING INSPECTION PROCEDURE .....	10
WHEEL STUD REMOVAL AND REPLACEMENT .....	10
PREPARING THE HUB FOR HUBODOMETER INSTALLATION .....	11



## SERVICE NOTES

This publication provides removal, installation and maintenance instructions for the HUS™ wheel-end. Before you begin:

- Read and understand all instructions and procedures before servicing any component.
- Read and observe all Caution and Warning statements to help avoid personal injury or property damage.
- Follow your company's maintenance, service, installation and diagnostic practices.

Hendrickson reserves the right to make changes and improvements to its products and publications at any time. Consult the Hendrickson website ([www.hendrickson-intl.com](http://www.hendrickson-intl.com)) for the latest version of this manual.

## IMPORTANT SAFETY NOTICE

Proper maintenance, service and repair is important to the reliable operation of the HUS™ wheel-end. The procedures recommended by Hendrickson and described in this publication are methods of performing such maintenance, service and repair.

The warnings and cautions should be read carefully to help prevent personal injury and to assure that proper methods are used. Improper maintenance, service or repair can cause damage to the wheel-end and other property, personal injury, an unsafe operating condition or void the manufacturer's warranty.

Carefully read, understand and follow all safety related information within this publication.

## EXPLANATION OF SIGNAL WORDS

Hazard signal words (such as Danger, Warning or Caution) appear in various locations throughout this publication. Information accented by one of these signal words must be observed at all times. Additional notes are utilized to emphasize areas of procedural importance and provide suggestions for ease of repair. The following definitions indicate the use of these signal words as they appear throughout the publication.

**DANGER** Indicates immediate hazards which will result in severe personal injury or death.

**WARNING** Indicates hazards or unsafe practices which could result in severe personal injury or death.

**CAUTION** Indicates hazards or unsafe practices which could result in damage to machine or minor personal injury.

**IMPORTANT** An operating procedure, practice or condition that is essential to emphasize.

**⚠ WARNING: DO NOT MODIFY OR REWORK PARTS. DO NOT USE SUBSTITUTE PARTS OF THE WHEEL-END. USE OF A MODIFIED PART OR REPLACEMENT PART NOT AUTHORIZED BY HENDRICKSON MAY NOT MEET HENDRICKSON'S SPECIFICATIONS AND CAN RESULT IN FAILURE OF THE PART, LOSS OF VEHICLE CONTROL AND POSSIBLE PERSONAL INJURY OR PROPERTY DAMAGE. USE ONLY HENDRICKSON AUTHORIZED REPLACEMENT PARTS. DO NOT MODIFY PARTS WITHOUT AUTHORIZATION FROM HENDRICKSON.**

**⚠ CAUTION: A mechanic using a service procedure or tool which has not been recommended by Hendrickson must first satisfy himself that neither his safety nor the vehicle's safety will be jeopardized by the method or tool selected. Individuals deviating in any manner from the provided instructions assume all risks of consequential personal injury or damage to equipment.**

**⚠ WARNING: ALWAYS WEAR PROPER EYE PROTECTION AND OTHER REQUIRED PERSONAL PROTECTIVE EQUIPMENT WHEN PERFORMING VEHICLE MAINTENANCE, REPAIR OR SERVICE.**

## PREPARING THE TRAILER FOR SERVICE

**⚠ WARNING: TO PREVENT SERIOUS EYE INJURY, ALWAYS WEAR SAFETY GLASSES WHEN PERFORMING TRAILER MAINTENANCE AND SERVICE.**



HUST™ Wheel End (BTF-0083) Replacement Parts  
(contact Chicago Rawhide at 800-882-0008)

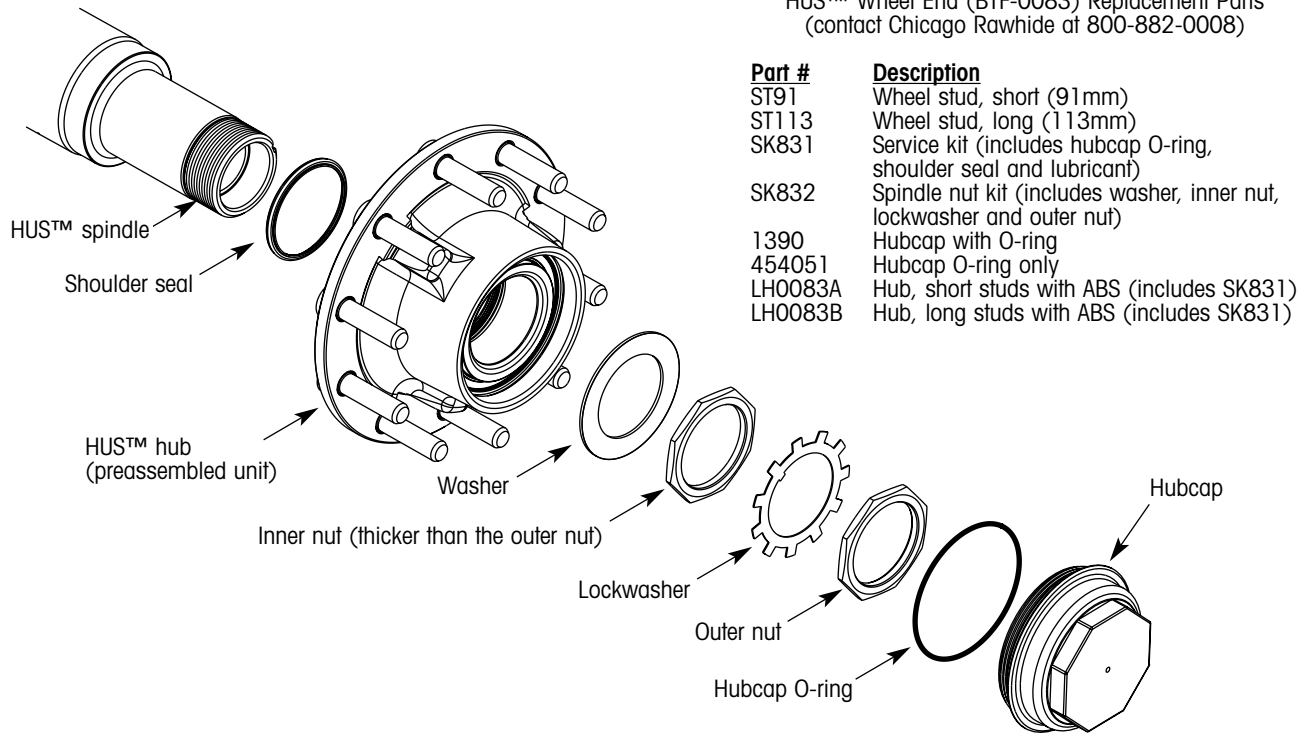

Figure 1. HUST™ wheel end parts identification

1. Park the trailer on a level, debris-free surface.
2. To prevent the trailer from moving, chock the wheels of the axle not being raised.
3. Using a jack, raise the axle until the trailer wheels clear the work surface.
4. Support the raised axle with safety stands.

**⚠ WARNING: DO NOT WORK UNDER A TRAILER SUPPORTED ONLY BY JACKS. JACKS CAN SLIP OR FALL OVER, RESULTING IN SERIOUS PERSONAL INJURY.**

## INTRODUCTION

The HUST™ hub (figure 1) is a permanently sealed and lubricated assembly designed to help reduce wheel-end maintenance.

The following features are unique to the HUS hub and help to distinguish it from the other hub assemblies found on INTRAAX® suspensions:

- It is constructed of steel and manufactured by SKF.
- The hubcap screws onto the hub and has no

provision for adding lubricant.

- Warranty and service information is stamped on the hubcap.
- The four piece axle spindle locking hardware consists of a washer, a thicker inner nut, a bendable tab lockwasher and a thinner outer nut. The inner nut is also stamped with installation information.

Because the spindle locking hardware is unique to the HUS hub, it is not interchangeable with other INTRAAX hub assemblies or other unitized hubs.

Except for the shoulder seal, hubcap, hubcap O-ring, wheel studs and lug nuts, there are no serviceable components in the HUS hub assembly. Should it become necessary, the entire HUS hub must be replaced as a complete assembly.

## INSPECTIONS AND INSPECTION INTERVALS

At regular intervals, the HUS hub should be checked for seal leaks, smooth rotation and end play.

In addition to the intervals listed below, these inspections should be done at each brake reline,



since the wheel end will be dismantled enough to make these inspections easy. In addition to the inspection at brake service, always maintain current shop preventive maintenance and pre-trip inspection practices.

## EVERY THREE MONTHS

Visually inspect the back of the hub and the hubcap for leakage. Refer to the section titled CHECKING FOR SEAL LEAKS for complete inspection details.

## EVERY 12 MONTHS OR 100,000 MILES (160,000 KM), WHICHEVER OCCURS FIRST

Visually inspect the back of the hub and the hubcap for leakage and check the HUS hub for smooth rotation. Refer to the section titled CHECKING FOR SMOOTH ROTATION for complete inspection details. If the hub feels rough, sounds noisy or does not rotate freely, contact the Hendrickson technical service department at 800-455-0043 in the United States or 800-668-5360 in Canada. They will provide further assistance.

## CHECKING FOR SEAL LEAKS

1. Check the back side of the hub.

The HUS™ hub gets filled with grease at the factory during the manufacturing process. The grease is contained in the hub by an integral inboard grease seal. A small amount of grease may be visible at this seal. **This is a normal occurrence and does not indicate a seal leak.** If this seal is leaking, a large quantity of grease will be present on the back side of the hub (figure 2). If you see this condition, replace the hub.

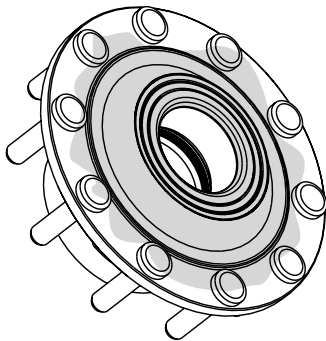

Figure 2. Check back side of hub for grease seal leak

During hub installation, a small amount of grease will appear at the spindle bearing shoulder to hub

joint (figure 3). **This is also normal and does not indicate a seal leak.**

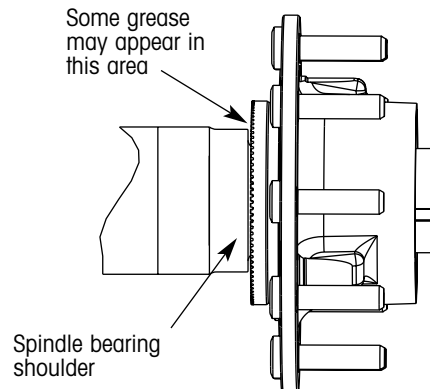

Figure 3. Normally present grease at spindle bearing shoulder

Small amounts of grease may also be visible on the other side of the hub at the hub outer seal (figure 4). **This is also a normal occurrence and does not indicate a seal leak.** However if a large amount of grease is visible, the seal is leaking and the hub should be replaced.

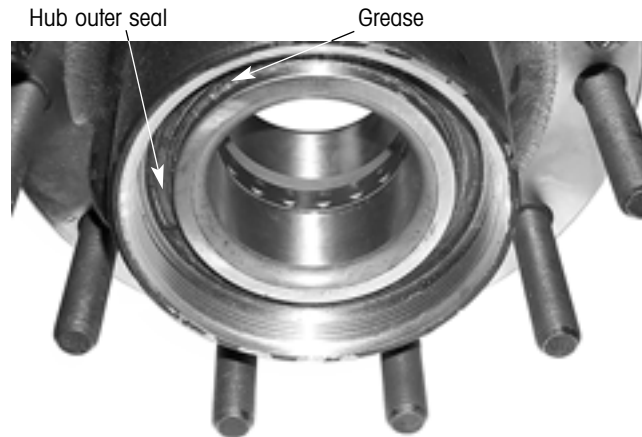

Figure 4. Normally present grease at hub outer seal

## CHECKING FOR SMOOTH ROTATION

1. Rotate the hub in both directions. Check for free, smooth and quiet rotation.
2. If the bearings feel rough or sound noisy, contact the Hendrickson technical service department.

## CHECKING END PLAY

This procedure should only be attempted when the rotation check reveals a rough feeling, noisy

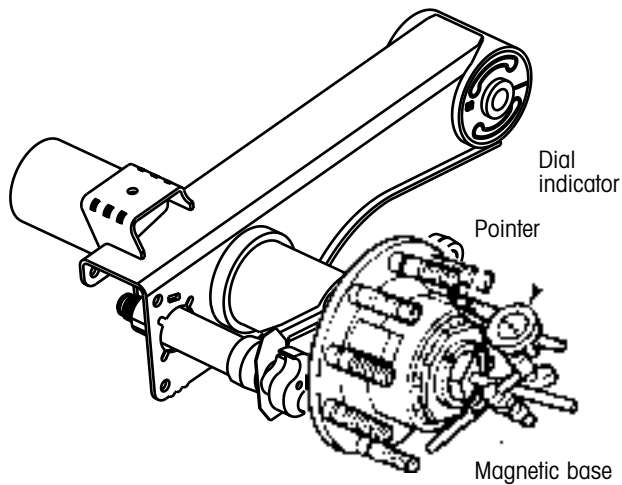

Figure 5. Attaching the dial indicator to check end play

sounding hub *and* the Hendrickson technical service department has advised you to perform this check.

1. Attach the magnetic base of a dial indicator to the end of the spindle.
2. Adjust the dial indicator so that its pointer touches the hub (figure 5).
3. Slightly rotate the hub in both directions while pushing the hub inward until the dial indicator reading remains constant (figure 6).
4. Zero the dial indicator.
5. Pull the hub outward until the dial indicator reading remains constant (figure 7). DO NOT rotate the hub.

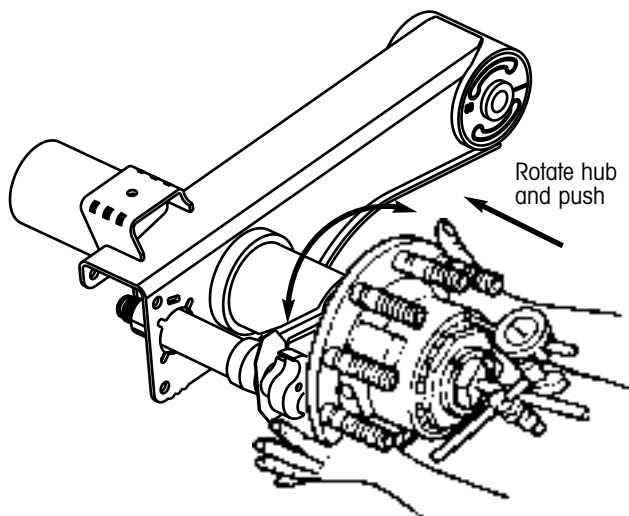

Figure 6. Push the hub inward while rotating in both directions

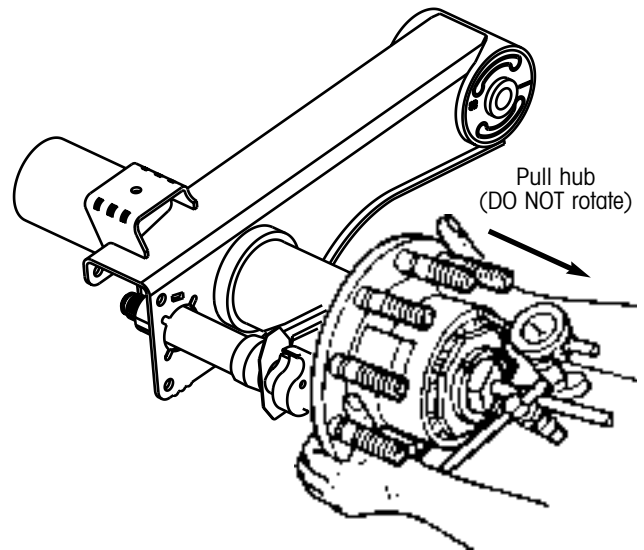

Figure 7. Pull the hub outward

6. Read the value on the dial indicator. This value indicates end play. Correct end play is between 0.000 and 0.005 in. If excess end play is identified (more than 0.005 in.), contact the Hendrickson technical service department at 800-455-0043 in the United States or 800-668-5360 in Canada. They will provide further assistance. DO NOT attempt to remove the hub without first contacting Hendrickson.

## REMOVAL

The HUST™ hub is a permanently sealed and lubricated assembly designed to help reduce wheel-end maintenance. Except for the shoulder seal, hubcap and hubcap O-ring, no individual component of the HUS hub assembly can be serviced. When necessary, the entire HUS hub must be replaced as an assembly.

**IMPORTANT:** Do not attempt to remove the hub bearings, seals or lubricant from the unitized assembly. Removal of these components will void the warranty.

Under normal operating conditions, it is not necessary to remove the HUS hub assembly from the axle. The only exception is when stripped or damaged wheel studs need to be replaced. If that is the case, use the following procedure to remove the HUS hub assembly.

1. Obtain an HUS hub service kit. Contact Chicago Rawhide at 800-882-0008 and ask for part number SK831.

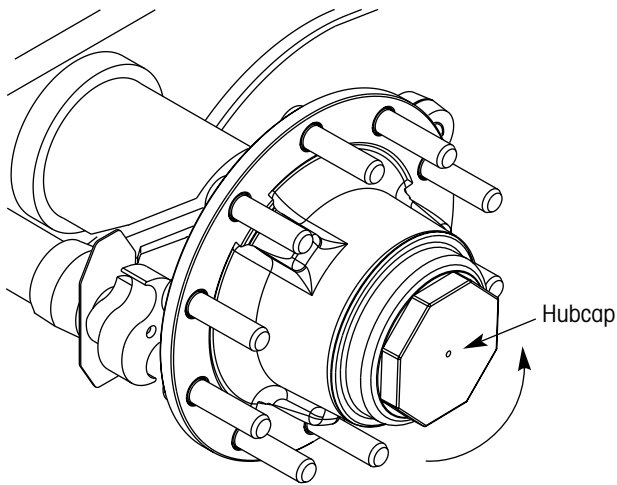

Figure 8. Removing the hubcap

The service kit consists of a tube of Molykote D lubricant, a shoulder seal and a hubcap O-ring. Whenever the HUS hub is removed from the spindle, the shoulder seal must be replaced, the entire spindle (except for the spindle threads) and hub bore must be wiped clean and relubricated with Molykote D and the hubcap O-ring must be inspected and replaced (if necessary). Refer to the HUBCAP O-RING INSPECTION PROCEDURE on page 10 for more inspection details.

- Remove the tire/wheel assembly.

**⚠ CAUTION:** Remove the wheel nuts to remove the tire/wheel assembly. Do not remove the inner and outer spindle nuts and then attempt to remove the tire/wheel assembly, brake drum and hub as an entire assembly. The clip inside the hub bore (figure 10) can dislodge, causing the hub to disassemble. Damage to components can result.

- Disengage the brake shoes and remove the brake drum.
- Remove the hubcap by rotating it counterclockwise (figure 8).
- Using a screwdriver or other suitable tool, straighten the two opposing flattened lockwasher tabs until they clear the outer nut (figure 9).

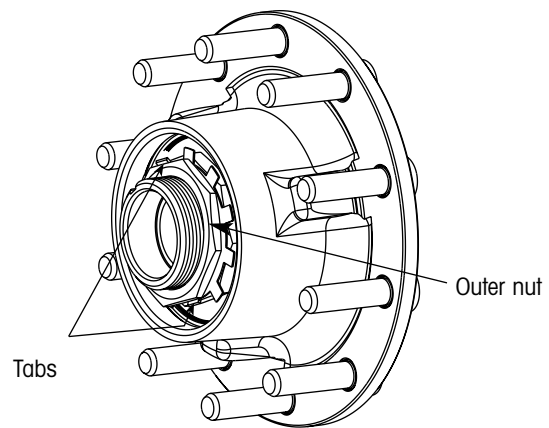

Figure 9. Straighten the lockwasher tabs

**⚠ CAUTION:** Keep the tool securely on the lockwasher tabs. If the tool slips off the tabs, damage to the hub outer seal can occur.

**NOTE:** Because of the high installation torque (700 lbs., 949 N•m), a torque multiplier may be useful when removing the inner and outer spindle nuts in the following step.

- Remove the outer spindle nut, lockwasher, inner spindle nut and washer (all items can be seen in figure 1). Use care when removing the inner spindle nut to prevent damage to the hub outer seal.

**NOTE:** With the outer nut, lockwasher, inner nut and washer removed, it is possible to see most of the hub outer seal. Small amounts of grease may be visible at the hub outer seal (figure 4). This is a normal occurrence and does not

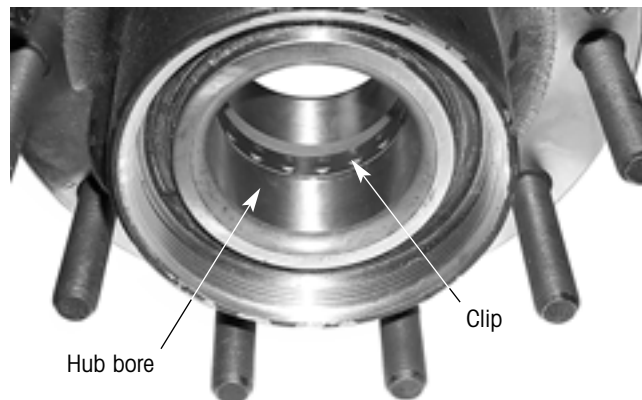

Figure 10. Avoid dislodging the clip inside the hub bore

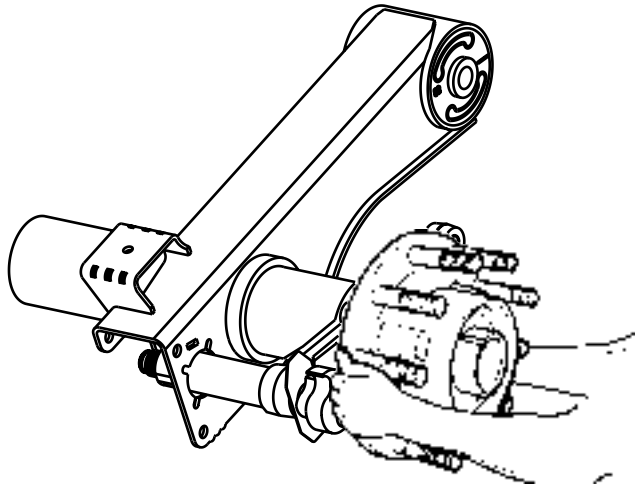

Figure 11. Removing the HUST™ hub

indicate a seal leak. However if a large amount of grease is visible, the seal is leaking and the hub must be replaced.

**⚠ WARNING:** WHEN REMOVING THE HUB ASSEMBLY FROM THE AXLE SPINDLE IN THE FOLLOWING STEP, CAREFULLY PULL THE HUB OFF THE SPINDLE AS STRAIGHT AS POSSIBLE TO AVOID DISLODGING THE CLIP INSIDE THE HUB BORE (FIGURE 10). IF THE CLIP BECOMES DISLODGED, THE HUB WILL DISASSEMBLE, WHICH CAN CONTAMINATE THE LUBRICANT AND VOID THE WARRANTY. DAMAGE TO COMPONENTS CAN RESULT.

**DO NOT ATTEMPT TO REBUILD A DISASSEMBLED HUB. TO AVOID COMPONENT DAMAGE, A NEW HUS HUB MUST BE INSTALLED.**

**⚠ CAUTION:** To prevent damage to the hub outer seal, keep all contaminants away from the seal when removing the hub.

7. Grasp the hub assembly with both hands (figure 11). If the hub assembly is free on the axle spindle, pull the hub as straight as possible to avoid dislodging the clip inside the hub bore. If the hub assembly is stuck on the axle spindle, use either one of the following procedures to remove the hub from the spindle:

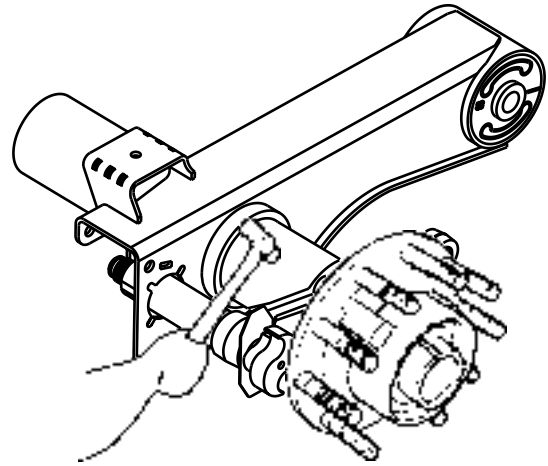

Figure 12. Tap lightly on axle to loosen hub

1. Tap lightly on the unmachined part of the axle with a hammer (figure 12). Tapping may loosen the hub assembly for easier removal.

OR

1. Attach a three-pronged puller to the hub.
  - a. Install a metal plate between the puller screw and the end of the spindle (figure 13).

**⚠ CAUTION:** To prevent damage to the end of the spindle, always use a metal plate between the puller screw and the end of the spindle.

- b. While holding the puller screw stationary, spin the hub to remove it from the axle (figure 13).

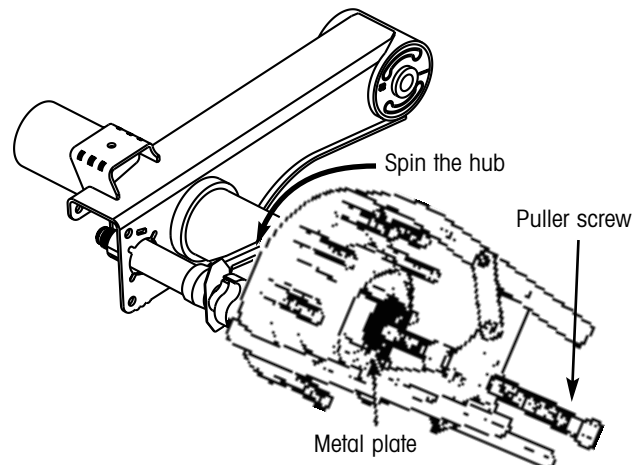

Figure 13. Removing the hub with a puller

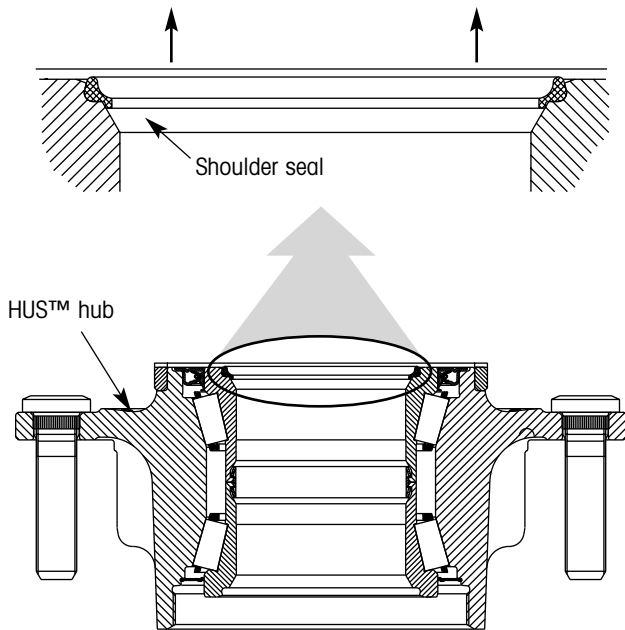

Figure 14. Shoulder seal location

- c. When the hub reaches the end of the spindle, pull the hub off the spindle as straight as possible to prevent dislodging the clip inside the hub bore.

**IMPORTANT:** If a puller is required to remove a stuck HUS hub, do not reinstall the same hub. Replace the hub.

## INSTALLATION

**NOTE:** A torque bar or torque multiplier capable of measuring at least 700 ft. lbs. (949 N•m) of torque is required to install the HUS™ hub.

Whenever the HUS™ hub is removed from the spindle, the shoulder seal must be replaced before

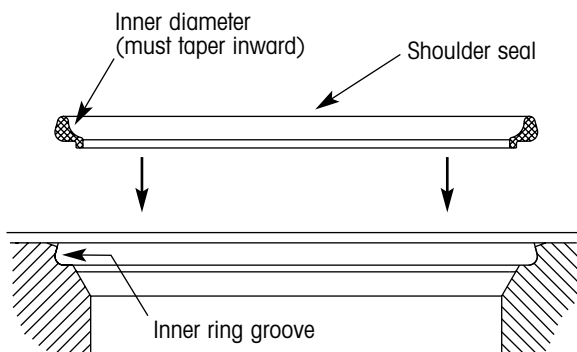

Figure 15. Shoulder seal installation details

the hub is installed. Use the following procedure to replace the shoulder seal.

1. Carefully remove the existing shoulder seal (figure 14). Take care not to scratch, nick or otherwise mark the hub bore when removing the seal.
2. Install the new shoulder seal into the inner ring groove (figure 15) in the hub. When properly oriented for installation, the shoulder seal inner diameter will taper inward. Do not force the shoulder seal into the inner ring groove.

**⚠ CAUTION:** To prevent damage to the hub outer seal, keep all contaminants away from the seal when installing the hub.

To prevent HUS hub component damage, do not use solvents to clean the hub bore. Solvents can enter the hub and contaminate the lubricant.

Do not attempt to install the hub, brake drum and tire/wheel assembly as an entire assembly. The clip inside the hub bore can dislodge, causing the hub to disassemble. Damage to components can result.

3. Remove the old grease from the axle spindle, axle threads and hub bore by wiping with a clean rag.
4. Check the axle spindle and hub bore for scratches, nicks or marks. If necessary, repair them with crocus or emery cloth.
5. Use your finger to verify that the hub side of the axle bearing shoulder and the side of the hub that contacts this shoulder are completely free of debris (figure 16).

**⚠ CAUTION:** Prevent debris from entering the joint between the hub and the axle bearing shoulder. If debris is trapped in this joint, it can create a gap that allows water to enter the axle spindle area and cause corrosion.

6. Use Molykote D spindle grease to lubricate the entire axle spindle (except the threads),

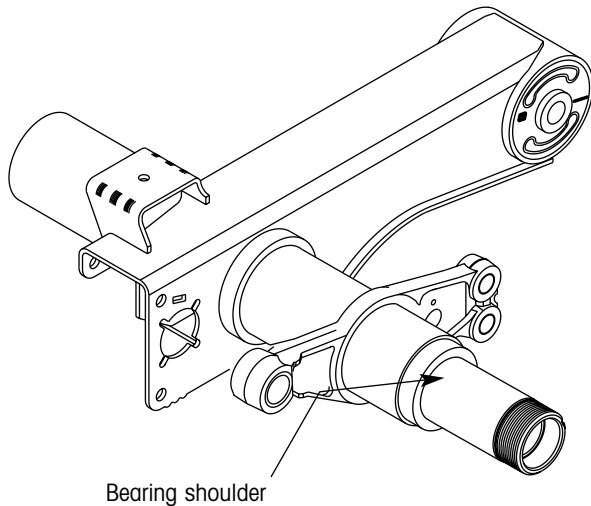

Figure 16. Make sure the bearing shoulder is free of debris

including the bearing journals and the hub side of the bearing shoulder. DO NOT allow any lubricant to get on the spindle threads.

**⚠ CAUTION:** When installing the hub assembly onto the spindle in the following step, align the hub bore straight onto the spindle to avoid dislodging the clip inside the hub bore (figure 10). If the clip becomes dislodged, the hub will disassemble, which can contaminate the lubricant and void the warranty.

**Do not attempt to rebuild a disassembled hub. To avoid component damage, A new HUS™ hub must be installed.**

**⚠ CAUTION:** When installing the hub assembly onto the spindle in the following step, do not force the hub assembly onto the spindle. The hub can jam on the spindle resulting in component damage. Also make sure the shoulder seal does not fall out of the inner ring groove. If the shoulder seal falls out of the groove, remove the hub and inspect the shoulder seal for tears before re-installing the shoulder seal and retrying the hub installation.

7. Carefully align the hub bore to the spindle and slide the hub straight onto the spindle. Tapping lightly on the unmachined part of the axle with a hammer may help ease hub installation. The hub is correctly installed when it contacts the spindle bearing shoulder.

Do not force the hub assembly onto the spindle. If the hub does not slide easily onto the spindle, carefully remove the hub so that you do not dislodge the clip inside the hub bore or damage the shoulder seal and repeat step seven until the hub is correctly aligned.

**NOTE:** It is normal to see a small bead of grease at the spindle bearing shoulder when the hub is installed onto the spindle.

8. Install the inner washer (figure 1).

**NOTE:** When installing the spindle nuts in the following steps, rotate the hub while tightening the nuts to the specified torque.

9. Install the inner nut (figure 1). While rotating the hub, use a torque wrench to tighten the inner nut to 700 ft. lbs. (949 N•m) of torque. Be careful not to damage the hub outer seal when tightening the inner nut.
10. Install the lockwasher (figure 1) and verify that the tab is correctly inserted into the spindle keyway.
11. Install the outer nut (figure 1). Use a torque wrench to tighten the outer nut to 250 ft. lbs. (340 N•m) of torque.
12. Bend two lockwasher tabs over opposing flats of the outer nut (figure 17).

**⚠ CAUTION:** When bending the lockwasher tabs, keep the tool securely on the tabs. If the tool slips off the tabs, damage to the hub outer seal can occur.

13. Inspect the hubcap O-ring and replace it if necessary. Refer to the HUBCAP O-RING INSPECTION PROCEDURE on page 10 for more inspection details.
14. If a new O-ring is required, install it by rolling it over the hubcap threads (figure 18).

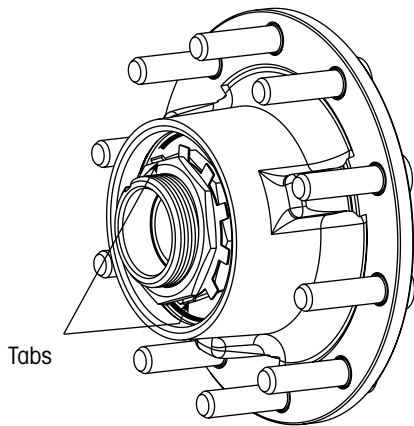

Figure 17. Bending opposing lockwasher tabs over the outer nut

15. Install the hubcap and tighten it to 50-75 ft. lbs. (68-102 N•m) of torque.

### HUBCAP O-RING INSPECTION PROCEDURE

The hubcap O-ring helps prevent moisture from entering the hub. A cracked or torn O-ring will allow moisture to pass through to the internal part of the hub, which can shorten the life of the hub. Therefore, the hubcap O-ring should be replaced if flat spots, cuts, tears or surface breakdown are observed.

### WHEEL STUD REMOVAL AND REPLACEMENT

Replacing a stripped or damaged wheel stud is the only service procedure that requires removing the HUS™ hub from the axle (except for hub replacement). When replacing a wheel stud, use only wheel studs manufactured for use with the HUS hub (part numbers ST91 for short studs or ST113 for long studs). Contact Chicago Rawhide at 800-882-0008 or [www.chicago-rawhide.com](http://www.chicago-rawhide.com) for complete sizing and ordering details. Use the following procedure to replace a damaged wheel stud on the HUS hub.

**⚠ WARNING: THE FOLLOWING PROCEDURE REQUIRES THE USE OF A HYDRAULIC PRESS. TO AVOID SERIOUS PERSONAL INJURY AND COMPONENT DAMAGE, OBSERVE ALL WARNINGS AND CAUTIONS PROVIDED BY THE HYDRAULIC PRESS MANUFACTURER.**

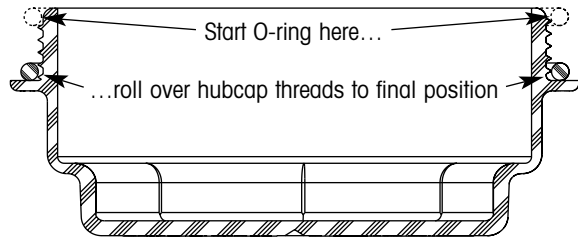

Figure 18. Hubcap O-ring installation details

1. Remove the hub following the REMOVAL instructions on page five.
2. Support the inboard side of the hub flange perpendicular to the press cylinder.
3. Use the press cylinder to push on the threaded end of the stud and force it out of the hub (figure 19).
4. Turn the hub over. Support the outboard side of the hub flange perpendicular to the press cylinder.
5. Use the press cylinder to push on the stud head, applying no more than 10,000 pounds (44,500N) of force to seat the new stud.
6. Install the hub following the INSTALLATION instructions on page eight.

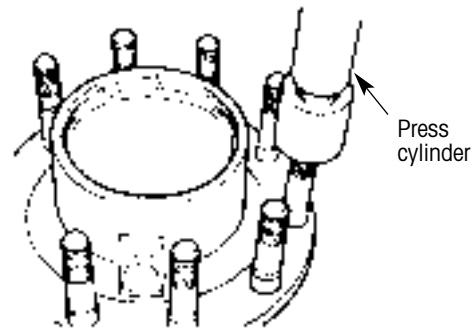

Figure 19. Removing a wheel stud

## PREPARING THE HUS HUB FOR HUBODOMETER INSTALLATION

Use the following procedure to prepare the HUS hub for hubodometer installation.

1. Remove the hubcap.
2. Using the pilot in the center of the hubcap (figure 20), drill a  $\frac{9}{16}$ -in. hole through the hubcap. Remove all drilling residue from the hubcap.
3. Install the hubodometer stud into the hole just drilled. Tighten the stud to the manufacturer's torque specification.
4. Remove and discard the existing hubcap O-ring.

**NOTE:** A new hubcap O-ring must be installed whenever the hubcap is removed.

5. Install a new O-ring by rolling it over the hubcap threads (figure 18).
6. Install the hubcap and tighten it to 50-75 ft. lbs. (68-102 N•m) of torque.

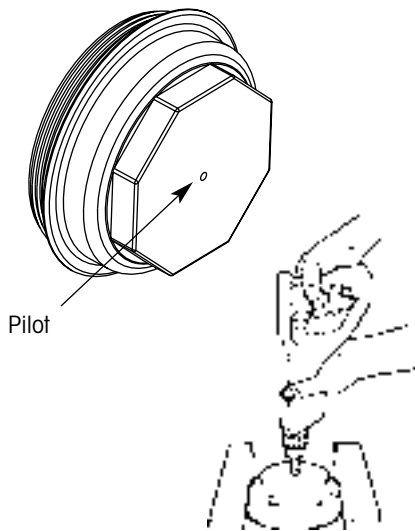

Figure 20. Preparing for hubodometer installation

Trailer Suspension Systems  
2070 Industrial Place SE  
Canton, OH 44707-2600 USA  
800.455.0043  
330.489.0045  
Fax 800.696.4416



Trailer Suspension Systems  
250 Chrysler Drive, Unit #3  
Brampton, ON L6S 6B6 Canada  
905.789.1030  
Fax 905.789.1033